

Product Technical Data Sheet

M6-11 RoofZips® Roofing Screw

Part Number	Description	Pack Qty	Pallet Qty
6-030-3306-1C4	M6-11 x 50 Hex Head RoofZips with Seal Climaseal 4	1000	84,000
6-030-5306-1C5	M6-11 x 50 Hex Head RoofZips with Seal Climaseal 5	1000	84,000
6-030-3307-2C4	M6-11 x 65 Hex Head RoofZips with Seal Climaseal 4	1000	60,000
6-030-5307-2C5	M6-11 x 65 Hex Head RoofZips with Seal Climaseal 5	1000	60,000

Application:

Buildex® M6-11 RoofZips® are designed for crest fixing roof sheets to top hat and timber battens.

Drilling Capacity:

Top Hat Batten - 0.55 mm ~ 0.75 mm | Timber - Pine and Hardwood | Steel Purlin - 1.2 mm ~ 1.5 mm

Installation Instructions:

1. Use a $\frac{5}{16}$ Hex Hexagon Driver Bit (Buildex® Part Number 1-991-1366-9).
2. Use a mains powered or cordless screw driver with a 3,000 RPM Max.
3. Fit the hex driver bit over the screw and place at the fastening position.
4. Apply consistently firm pressure (end load) to the screw driver until the screw has drilled and fastened.

Material: Carbon Steel SAE 1022 | **Heat Treatment:** To AS 3566.1 | **Finish:** Climaseal® 4 or Climaseal® 5.

Mechanical Properties:

Single Shear Strength (N) 8,500 | Axial Tensile Strength (N) 15,400 | Torsion Strength (N-m) 14.5

Pullout Values:

G550 0.55 mm Batten 1,520 | G550 0.75 mm Batten 2,480 | G450 1.2 mm Stud 3,280 | G450 1.5 mm Purlin 5,240 |

* F7 (Pine) Timber (N) 4,300 | Into F17 (Hardwood) Timber (N) 6,570

All values are averages obtained under laboratory conditions and appropriate safety factors should be applied for design purposes.

These figures are applicable to Buildex® head marked product only.

*Timber values are at 35.0 mm embedment.

Corrosion Performance:

Buildex® Cyclonic RoofZips with Climaseal® 4 complies to Australian Standards AS3566.2 Class 4, the Climaseal® 5 product is suitable for ISO Category 4 and 5.

Product Technical Data Sheet

M6-11 RoofZips® Roofing Screw

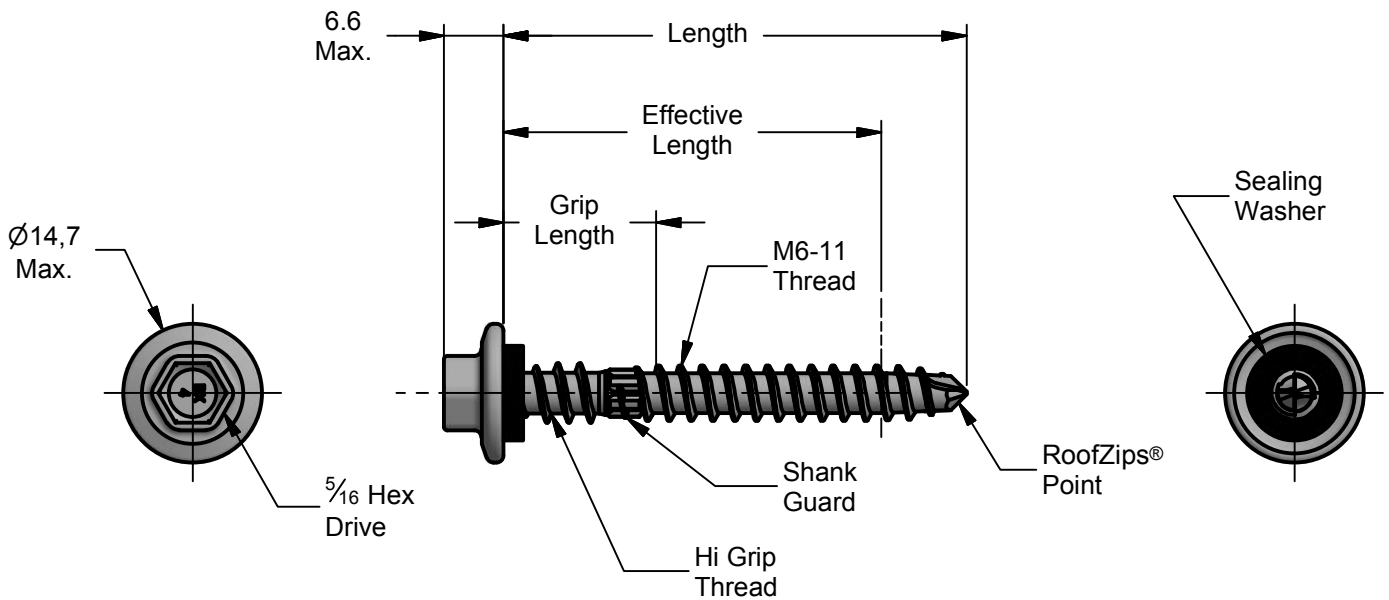

Description	Length	Grip Length	Effective Length
M6 -11 x 50 Hex Head RoofZips® with Seal	48.5 / 50.0	15.3 / 16.0	40.0 Min
M6 -11 x 65 Hex Head RoofZips® with Seal	63.5 / 65.0	30.3 / 31.0	55.0 Min.

All dimensions nominal unless otherwise stated. Normal manufacturing tolerances apply.

Buildex® Head Office
 600 South Road
 Moorabbin Victoria 3189
 Australia
 1300 368 101
 CustomerService-MBN@buildex.com.au
 Technical Help Desk
 Technicalhelpdesk@buildex.com.au