

Product Technical Data Sheet

12-11 Stainless Steel 304 Grade Stitch Screw

Part Number	Description	Pack Qty	Pallet Qty
6-117-0008-2	12-11 x 20 Hex Head Stitch Screw with 16mm ABW	500 / 2000	168,000

Application:

Buildex® 12-11 Hex Head Stainless 304 Stitch Screw is used for fixing unsupported overlaps of roof and side cladding when protection from a corrosive environments and or a complete system compatibility is crucial.

Product Compatibility with Cladding:

Refer to BlueScope Technical Bulletin TB-16

Drill Capacity:

	Aluminium Thickness 0.7mm ~ 1.2 mm		Aluminium Thickness 2 x 1.2 mm Max.
---	---------------------------------------	---	--

Features:

Hex Washer Head
AB Point
Material Finish

Benefits:

For positive drive
For piecing into sheet while ensuring maximum pullout strength and a high strip torque.
Stainless Steel Corrosion performance to suit the application.

Installation Instructions:

1. Use a Buildex® $\frac{5}{16}$ Hex Head Driver Bit (1-991-1366-9)
2. Use a mains powered or cordless screw driver with a 2,500 RPM speed.
3. Fit the $\frac{5}{16}$ driver bit into the screw and place at the fastening position.
4. Apply consistently firm pressure (end load) to the screw driver until the screw has fastened.

Material: Stainless Steel Grade 304 | **Heat Treatment:** Not applicable | **Finish:** Stainless Steel

Mechanical Properties:

Single Shear Strength (N) 7,200 | Axial Tensile (N) 11,900 | Torsion Strength 10.6 N.m

Pullouts:

0.7 mm Aluminium Single (N) 850 | 0.7 mm Aluminium Lapped (N) 1,350 | 0.9 mm Aluminium Single (N) 1,200 | 0.9 mm Aluminium Lapped (N) 1,400
1.2 mm Aluminium Single (N) 1,900 | 1.2 mm Aluminium Lapped (N) 3,300

All values are averages obtained under laboratory conditions and appropriate safety factors should be applied for design purposes. These figures are applicable to Buildex® head marked product only.

Corrosion Performance:

Stainless Steel

Product Technical Data Sheet

12-11 Stainless Steel 304 Grade Stitch Screw

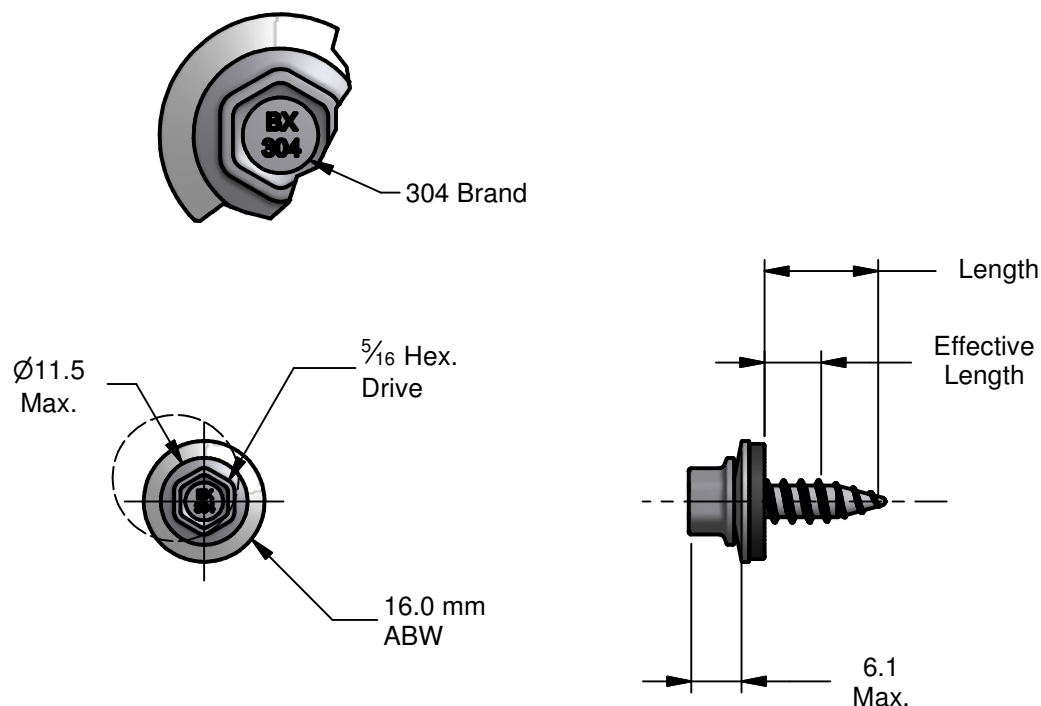

Description	Length	Effective Length
12-11 x 20 Hex Head Stainless 304 Stitch Screw with 16.0 mm ABW	14.0 / 15.5	4.3 Max.

All dimensions nominal unless otherwise stated. Normal manufacturing tolerances apply.

Buildex® Head Office
 600 South Road
 Moorabbin Victoria 3189
 Australia
 1300 368 101
 CustomerService-MBN@buildex.com.au
 Technical Help Desk
 Technicalhelpdesk@buildex.com.au