

Product Technical Data Sheet

5/16-12 x 17 Hex Head Trusstite

Part Number	Description	Pack Qty	Pallet Qty
6-181-0011-1CS	5/16-12 x 17 Hex Head Trusstite, Climaseal® 3	2,000	157,000

Application:

BuildexA $\frac{5}{16}$ Hex Head TrussTiteA Screw is used for the assembly of steel roof trusses and floor trusses into pre-punched holes.

Features:

5/16 Hex Drive

TrussTite Thread

5/16 Thread

Self Tapping Point

Benefits:

Easy to drive.

Ensures maximum pullout strength and a higher strip torque.

High single shear and torsional strength.

Easy to start and align.

Installation Instructions:

1. Use a BuildexA $\frac{5}{16}$ Hex Head Driver Bit (BuildexA Part 1-991-1366-9)
2. Use a mains powered or cordless screw driver with a 2,500 RPM speed.
3. Fit the BuildexA $\frac{5}{16}$ driver bit into the screw and place at the fastening position.
4. Apply consistently firm pressure (end load) to the screw driver until the screw has fastened.

Material: Carbon Steel SAE 1022 | **Heat Treatment:** To AS 3566.1 | **Finish:** ClimasealA 3

Mechanical Properties:

Single Shear Strength (N) 18,000

Pullout Values (N) into steel frame section (MM):

Steel Frame Section 0.55: 1,200 | Steel Frame Section 0.75: 1,900 | Steel Frame Section 1.00: 2,850

Steel Frame Section 1.20: 3,750

All values are averages obtained under laboratory conditions and appropriate safety factors should be applied for design purposes.

These figures are applicable to Buildex head marked product only.

Corrosion Performance:

The BuildexA $\frac{5}{16}$ Hex Head TrussTite Screw complies to Australian Standards AS3566.2 Class 3

Recommended Punched Hole Sizes:

Steel Section 0,75 x 2: punch hole dia 6.9 / 7.1

Steel Section 1,00 x 2: punch hole dia 7.1 / 7.3

Steel Section 1,20 x 2 punched hole diameter 7.2 / 7.4

Steel Section 1,6 punched hole diameter 7.5 / 7.6

Product Technical Data Sheet

5/16-12 x 17 Hex Head Trusstite

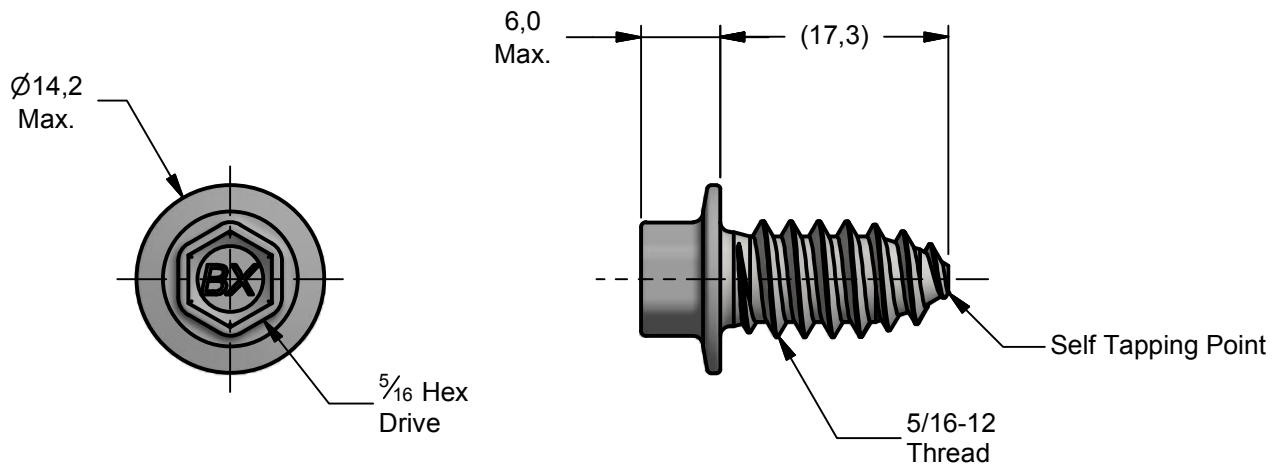

All dimensions nominal unless otherwise stated. Normal manufacturing tolerances apply.

Buildex® Head Office
600 South Road
Moorabbin Victoria 3189
Australia
1300 368 101
CustomerService-MBN@buildex.com.au

Buildex® Middle Eastern Sales Office
middleeastsales@buildex.com.au

Technical Help Desk
Technicalhelpdesk@buildex.com.au