

Product Technical Data Sheet

5/16-12 x 17 Smooth Top Trustite

Part Number	Description	Pack Qty	Pallet Q
6-181-0013-3MP	5/16-12 x 17 Smooth Top Trustite, Climaseal 3	2,000	157,000

Application:

Buildex® 5/16 Smooth Top TrussTite Screw is used for the assembly of steel roof trusses, Steel house frames and floor trusses into pre-punched holes.

Features:

Low Profile Head

Underhead serrations

Recess Drive

TrusTite Thread

5/16 Thread

Self Tapping Point

Benefits:

The head sits flush or below the punched dimple in the house frame

Has a higher resistance to loosening and a higher strip torque.

Easy to drive allows for a low head profile.

Ensures maximum pullout strength and a higher strip torque.

High single shear and torsional strength.

Easy to start and align.

Installation Instructions:

1. Use a Buildex® Number 3 Phillip Recess Driver Bit (Buildex® Part 6-991-0395-5)
2. Use a mains powered or cordless screw driver with a 1,500 RPM maximum speed.
3. Fit the Buildex® Cross Recess driver bit into the screw and place at the fastening position.
4. Apply consistently firm pressure (end load) to the screw driver until the screw has fastened.

Material: Carbon Steel SAE 1022 **Heat Treatment:** To AS 3566.1 **Finish:** Climaseal® 3

Mechanical Properties:

Single Shear Strength (N) 18,000

All values are averages obtained under laboratory conditions and appropriate safety factors should be applied for design purposes. These figures are applicable to Buildex® head marked product only.

Corrosion Performance:

The Buildex® 5/16 Smooth Top TrussTite Screw complies to Australian Standards AS3566.2 Class 3

Recommended Punched Hole Sizes:

Steel Section 0,75 x 2: punch hole dia 6.9 / 7.1

Steel Section 1,00 x 2: punch hole dia 7.1 / 7.3

Steel Section 1,20 x 2 punched hole diameter 7.2 / 7.4

Steel Section 1,6 punched hole diameter 7.5 / 7.6

Product Technical Data Sheet

5/16-12 x 17 Smooth Top Trustite

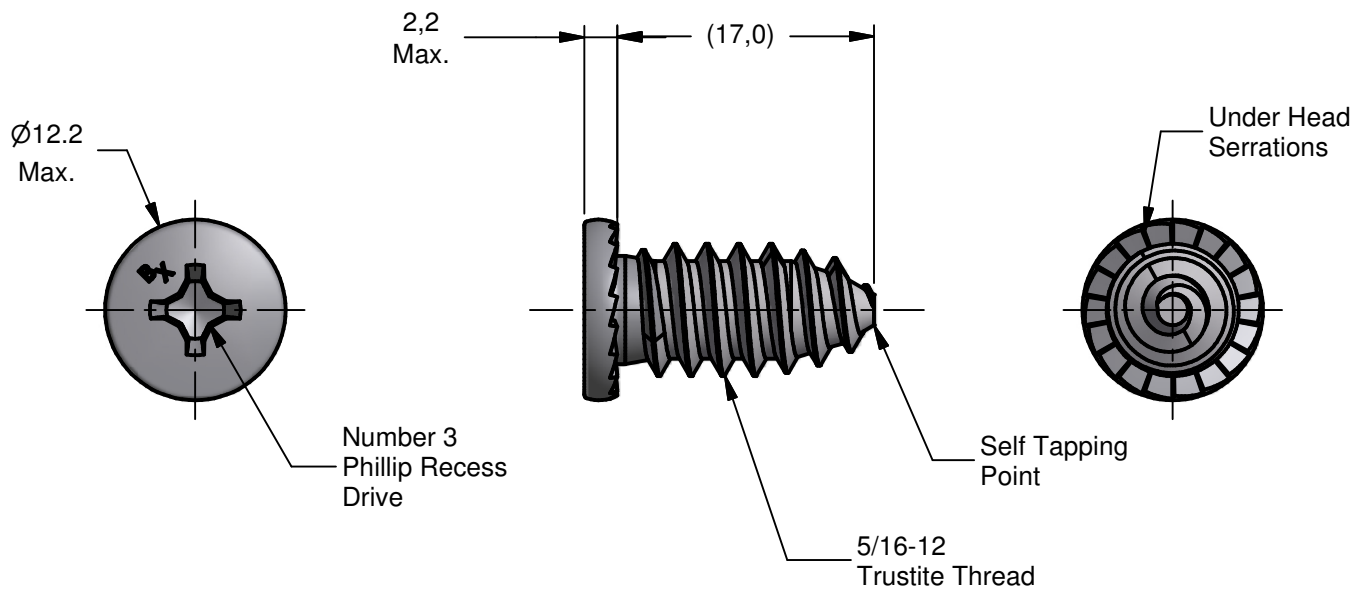

All dimensions nominal unless otherwise stated. Normal manufacturing tolerances apply.

Buildex® Head Office
600 South Road
Moorabbin Victoria 3189
Australia
1300 368 101
CustomerService-MBN@buildex.com.au

Buildex® Middle Eastern Sales Office
middleeastsales@buildex.com.au

Technical Help Desk
Technicalhelpdesk@buildex.com.au