

## Product Technical Data Sheet

### 10-16 Self Embedding Head AW Pt

Part Number	Description	Pack Qty	Pallet Qty
6-031-0251-6MP	10-16 x 45 Self Embedding Head AW Pt Climaseal® 3	500 / 2,000	168,000

#### Application:

The Buildex® 10-16 x 45 Self Embedding Head AW Point Screw is used for fixing compressed cement sheet to metal.

#### Drill Capacity:

Steel 1.2 mm ~ 2.4 mm x 2

#### Features:

Special Head

AW Tek® Point

Finish

#### Benefits:

For easy embedment into compressed cement sheet

For drilling into the compressed cement sheet and steel while ensuring maximum pullout strength and a high strip torque.

Corrosion performance Climaseal 3 to suit the application.

#### Installation Instructions:

1. Use a Buildtex® Number 2 Cross Recess Driver Bit (Part 1-991-1210-3)
2. Use a mains powered or cordless screw driver with a 2,500 RPM speed.
3. Fit the driver bit into the screw and place at the fastening position.
4. Apply consistently firm pressure (end load) to the screw driver until the screw has fastened.

**Material:** Carbon Steel SAE 1022 | **Heat Treatment:** To AS 3566.1 | **Finish:** Climaseal® 3

#### Mechanical Properties:

Single Shear Strength (N) 6,000 | Axial Tensile (N) 12,000 | Torsion Strength 8,5 N-m

#### Pullout Values (N):

Steel Stud 1.2 mm : 2,250 | Steel Purlin 1.5 mm : 3,990 | Steel Purlin 1.9 mm : 5,700 | Steel Purlin 2.4 mm : 7,270

All values are averages obtained under laboratory conditions and appropriate safety factors should be applied for design purposes.

These figures are applicable to Buildex® head marked product only.

#### Corrosion Performance:

10-16 x 45 Self Embedding Head AW Point Screw complies to Australian Standards AS3566.2 Class 3

## Product Technical Data Sheet

### 10-16 Self Embedding Head AW Pt

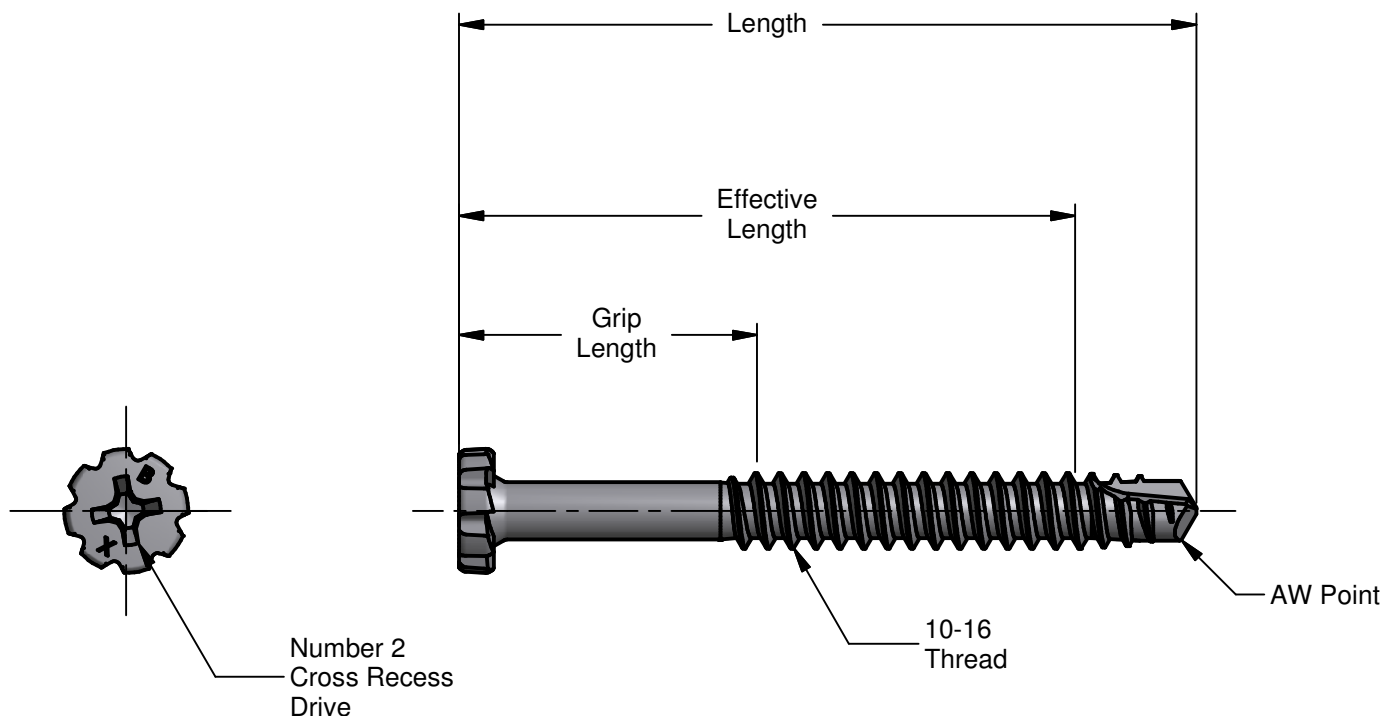

Description	Length	Grip Length	Effective Length
10-16 x 45 Self Embedding Head AW Pt Climaseal 3	45.5 / 47.0	15.5 / 17.5	30.0 Min

All dimensions nominal unless otherwise stated. Normal manufacturing tolerances apply.

Buildex® Head Office  
 600 South Road  
 Moorabbin Victoria 3189  
 Australia  
 1300 368 101  
 CustomerService-MBN@buildex.com.au

Buildex® Middle Eastern Sales Office  
 middleeastsales@buildex.com.au

Technical Help Desk  
 Technicalhelpdesk@buildex.com.au