

## Product Technical Data Sheet

### 8-15 Slotted Hex Washer Twin Start Needle Pt Screw

Part Number	Description	Pack Qty	Pallet Qty
6-241-0090-5MP	8-15 x 15 Hex Head Twin Start Needle Pt Climaseal 3	1000 / 8000	576,000
6-240-0090-5MP	8-15 x 15 Hex Head Twin Start Needle Pt Climaseal 3 with Seal	1000 / 8000	576,000

#### Application:

Buildex® 8-15 Slotted Hex Head Twin Start Needle Pt Screw is used for general fixing through light weight steel and stitching light gauge steel sheet. The product is also suitable for fixing into timber.

#### Drilling and Thread forming Capacity:

Steel: Total material thickness 0.5 mm ~ 2 | Timber: F7 ~ F17

#### Features:

Hex Drive  
Slotted Head  
Serrations  
8-15 Thread  
8-15 Thread  
Needle Point

#### Benefits:

For positive drive under high installation torque  
For Easy removal with a Bladed Screw Driver  
To reduce thread stripping  
For maximum pullout strength and a higher strip torque.  
High single shear and torsional strength.  
Does not require pre drilling.

#### Installation Instructions:

1. Use the Buildex® 1/4 Hex Driver Bit (Part Number i-991-i360-3)
2. Use a mains powered or cordless screw driver with a 2,500 RPM speed.
3. Fit the Hex Driver bit over the screw head and place at the fastening position.
4. Apply consistently firm pressure (end load) to the screw driver until the screw has fastened.

**Material:** Carbon Steel SAE 1022 | **Heat Treatment:** To AS 3566.1 | **Finish:** Climaseal® 3

#### Mechanical Properties:

Single Shear Strength (N) 4,100 | Axial Tensile Strength (N) 4,200 | Torsion Strength 3.4 N-m

All values are averages obtained under laboratory conditions and appropriate safety factors should be applied for design purposes.

These figures are applicable to Buildex® head marked product only.

#### Corrosion Performance:

Climaseal® 3 Products comply to Australian Standards AS3566.2 Class 3

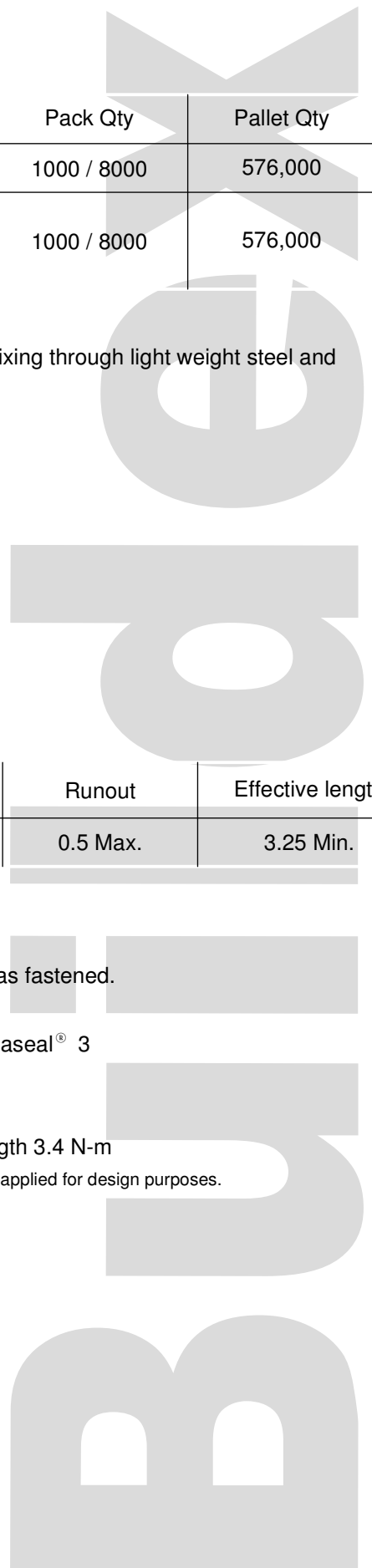

## Product Technical Data Sheet

### 8-15 Slotted Hex Washer Twin Start Needle Pt Screw

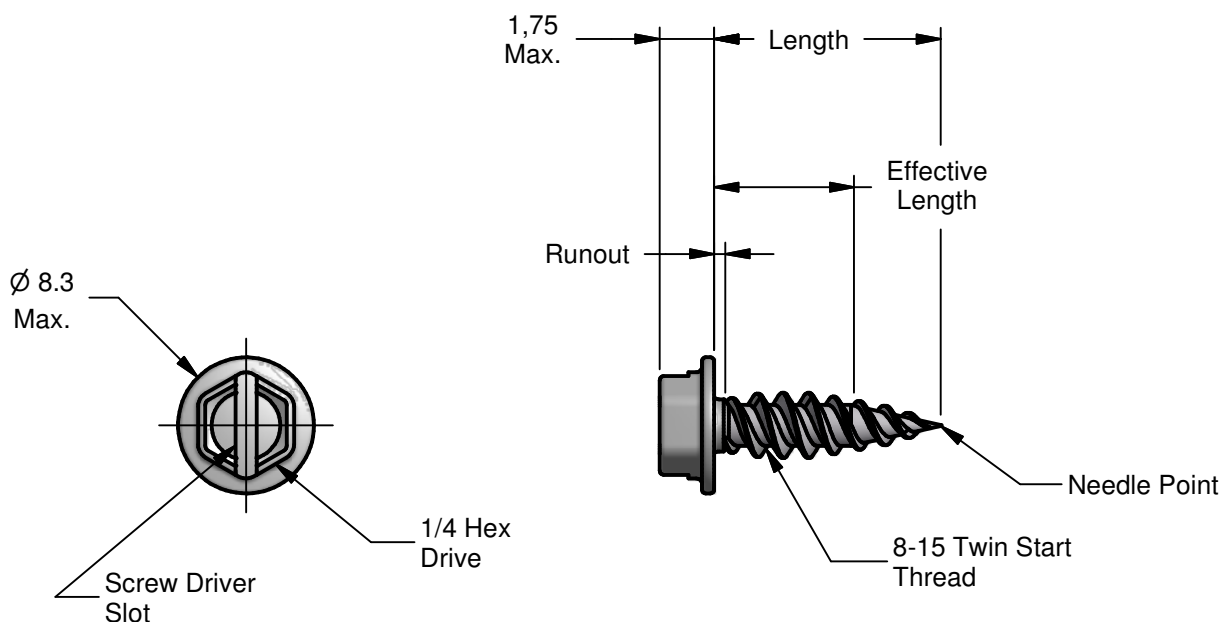

Description	Length	Runout	Effective length
8-15 x 15 Slotted Hex Head Twin Start Needle Pt Screw	14.0 / 16.0	0.5 Max.	3.25 Min.

All dimensions nominal unless otherwise stated. Normal manufacturing tolerances apply.

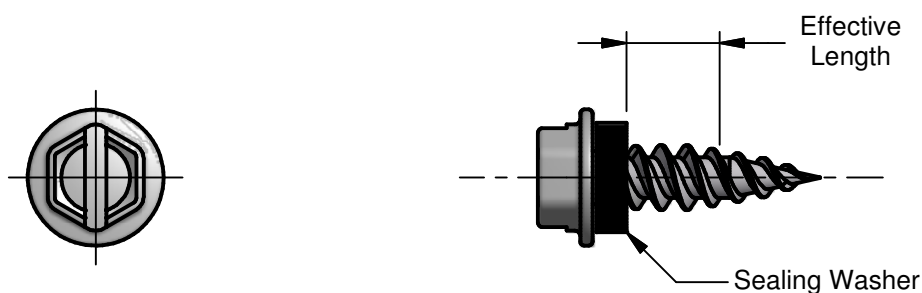

Part Number	Effective length
8-15 x 15 Slotted Hex Head Twin Start Needle Pt Screw with Seal	2.25 Min.

Buildex® Head Office  
 600 South Road  
 Moorabbin Victoria 3189  
 Australia  
 1300 368 101  
 CustomerService-MBN@buildex.com.au  
 Technical Help Desk  
 Technicalhelpdesk@buildex.com.au