

Product Technical Data Sheet

8-18 Button Head TekS

Part Number	Description	Pack Qty	Pallet Qty
6-311-0352-7	8-18 x 12 Button Head TekS Zinc Yellow	1000 / 8000	
6-311-0402-1	8-18 x 16 Button Head TekS Zinc Yellow	1000 / 6000	
6-311-0376-9	8-18 x 25 Button Head TekS Zinc Yellow	1000 / 4000	

Application:

Buildex® 8-18 Button Head TekS® Screw is used for when a broad flat head is needed such a foil sarking, insulation panels, and conduit clips to metal.

Drilling Capacity:

Steel 0.75 mm to 2.5 mm.

Features:

Button Head
TekS® Point

Benefits:

For for broad coverage.
For drilling into steel without pre drilling.

Installation Instructions:

1. Use a Buildex® Number 2 Phillips Recess Driver Bit (Part 1-991-4201-3)
2. Use a mains powered or cordless screw driver with a 3,000 RPM speed max.
3. Fit the driver bit into the screw and place at the fastening position.
4. Apply consistently firm pressure (end load) to the screw driver until the screw has fastened.

Material: Carbon Steel SAE 1022 | **Heat Treatment:** To AS 3566.1 | **Finish:** Zinc Yellow

Mechanical Properties:

Single Shear Strength (N) 5,100 | Axial Tensile (N) 6,300 | Torsion Strength 5.9 N-m

Pullout Values (N):

Steel Stud 0.75mm : 1,750 | Steel Stud 1.0mm: 2,300 | Steel Stud 1.2mm: 2,900 | Steel Purlin 1.5mm: 3,700

Steel Purlin 1.9mm: 2,800 | Steel Purlin 2.4mm: 6,300

All values are averages obtained under laboratory conditions and appropriate safety factors should be applied for design purposes.

These figures are applicable to Buildex® head marked product only.

Product Technical Data Sheet

8-18 Button Head Tekes

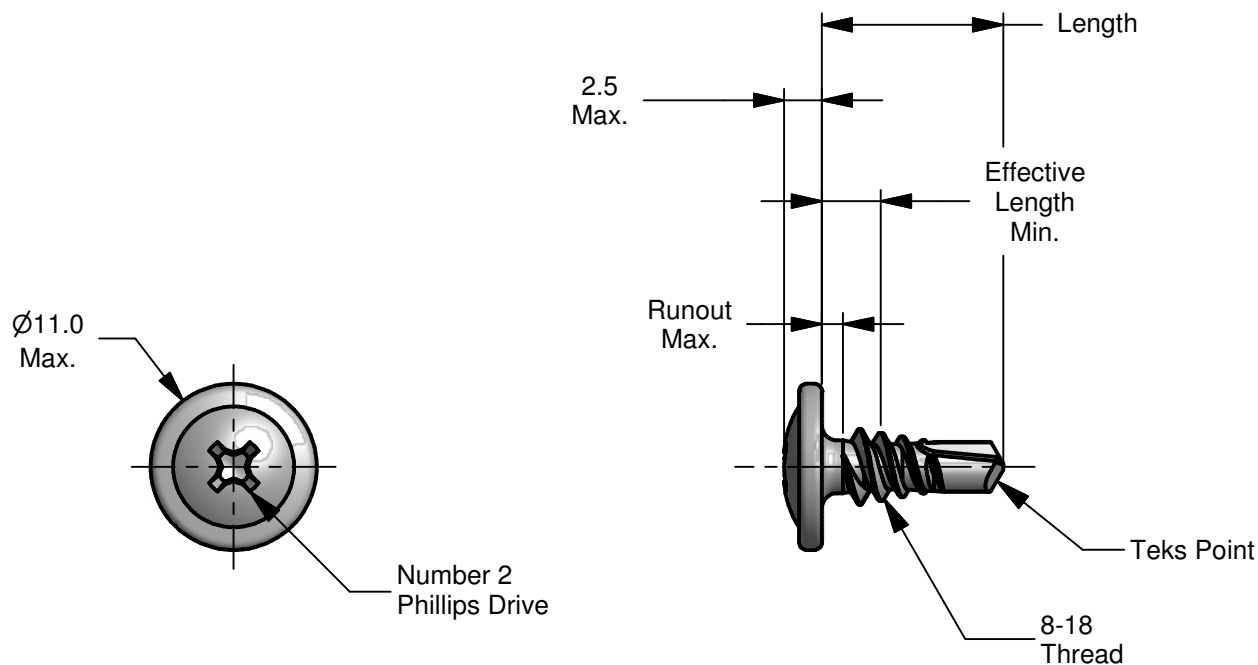

Description	Length	Grip Length	Effective length Min.
8-18 x 12 Button Head Tekes Zinc Yellow	10.5 / 12.0.0	7.0 Max.	0.25
8-18 x 16 Button Head Tekes Zinc Yellow	14.5 / 16.0	7.0 Max.	4.25
8-18 x 25 Button Head Tekes Zinc Yellow	23.5 / 25.0	7.0 Max.	13.25

All dimensions nominal unless otherwise stated. Normal manufacturing tolerances apply.

Buildex® Head Office
 600 South Road
 Moorabbin Victoria 3189
 Australia
 1300 368 101
 CustomerService-MBN@buildex.com.au
 Technical Help Desk
 Technicalhelpdesk@buildex.com.au