

Product Technical Data Sheet

8-18 Hex Head TekS Climaseal 3

Part Number	Description	Pack Qty	Pallet Qty
6-311-0008-1CS	8-18 x 12 Hex Head TekS Climaseal 3	1000 / 8000	576,000
6-310-0059-6CS	8-18 x 12 Hex Head TekS with Seal Climaseal 3	1000 / 8000	576,000

Application:

Buildex® 8-18 Hex Head TekS® Climaseal 3® Screw is used for metal to metal.

Drilling Capacity:

Steel 0.75 mm to 2.5 mm.

Features:

Button Head

TekS® Point

Benefits:

For for broad coverage.

For drilling into steel without pre drilling.

Installation Instructions:

1. Use a Buildex® 1/4 Hex Driver Bit (Part 1-991-1360-3)
2. Use a mains powered or cordless screw driver with a 3,000 RPM speed max.
3. Fit the driver bit into the screw and place at the fastening position.
4. Apply consistently firm pressure (end load) to the screw driver until the screw has fastened.

Material: Carbon Steel SAE 1022 | **Heat Treatment:** To AS 3566.1 | **Finish:** Zinc Yellow

Mechanical Properties:

Single Shear Strength (N) 5,100 | Axial Tensile (N) 6,300 | Torsion Strength 5.9 N-m

Pullout Values (N):

Steel Stud 0.75mm : 1,750 | Steel Stud 1.0mm: 2,300 | Steel Stud 1.2mm: 2,900 | Steel Purlin 1.5mm: 3,700

Steel Purlin 1.9mm: 2,800 | Steel Purlin 2.4mm: 6,300

All values are averages obtained under laboratory conditions and appropriate safety factors should be applied for design purposes.

These figures are applicable to Buildex® head marked product only.

Product Technical Data Sheet

8-18 Hex Head Teks Climaseal 3

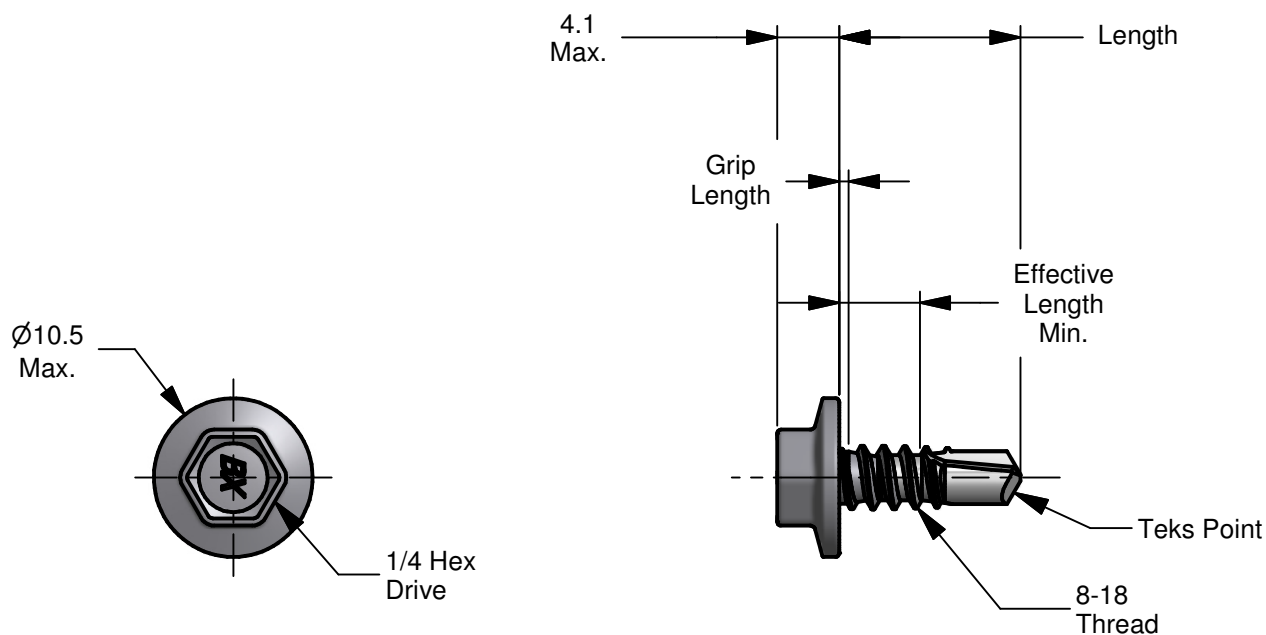

Description	Length	Grip Length	Effective length Min.
8-18 x 12 Hex Head Teks Climaseal 3	10.5 / 12.0.0	2.3 Max.	7.0 Max.

All dimensions nominal unless otherwise stated. Normal manufacturing tolerances apply.

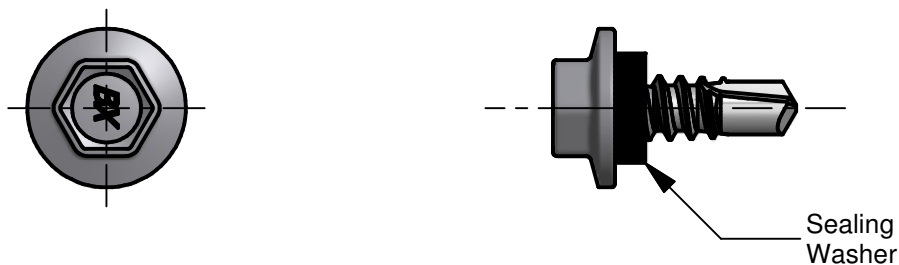

Buildex® Head Office
 600 South Road
 Moorabbin Victoria 3189
 Australia
 1300 368 101
 CustomerService-MBN@buildex.com.au
 Technical Help Desk
 Technicalhelpdesk@buildex.com.au