

Product Technical Data Sheet

10-16 Hex Head TekS

Part Number	Description	Pack Qty	Pallet Qty
6-311-3151-1C4	10-16 x 16 Hex Head TekS Climaseal 4	1000 / 4000	288,000
6-311-3398-1C4	10-16 x 25 Hex Head TekS Climaseal 4	1000 / 4000	288,000
6-310-3117-5C4	10-16 x 16 Hex Head TekS with Seal Climaseal 4	1000 / 4000	288,000
6-310-3398-8C4	10-16 x 25 Hex Head TekS with Seal Climaseal 4	1000 / 4000	288,000

Application:

Buildex® 10 -16 Hex Washer TekS® Screws are used for fixing wall cladding to steel purlins, and metal to metal applications such as fencing, signs, fixings and trailers.

Drill Capacity:

Steel 0.75 mm ~ 2.4 x 2

Features:

Hex Drive
TekS® Point
Finish

Benefits:

For positive drive under high installation torque
For drilling into steel while ensuring maximum pullout strength and a high strip torque.
Corrosion performance Climaseal 4

Installation Instructions:

1. Use a Buildex® $\frac{5}{16}$ Hex Head driver bit (Part 1-991-1366-9)
2. Use a mains powered or cordless screw driver with a 2,500 RPM speed.
3. Fit the Buildex® $\frac{5}{16}$ driver bit into the screw and place at the fastening position.
4. Apply consistently firm pressure (end load) to the screw driver until the screw has fastened.

Material: Carbon Steel SAE 1022 | **Heat Treatment:** To AS 3566.1 | **Finish:** Climaseal® 4

Mechanical Properties:

Single Shear Strength (N) 6,000 | Axial Tensile (N) 12,000 | Torsion Strength 8,5 N-m

Pullout Values (N):

Batten 0.75: 1,860 | Steel Purlin 1.2: 2,320 | Steel Purlin 1.5: 4,200 | Steel Purlin 1.9: 5,500 | Steel Purlin 2.4: 7,820

All values are averages obtained under laboratory conditions and appropriate safety factors should be applied for design purposes.
These figures are applicable to Buildex head marked product only.

Corrosion Performance:

10 -16 Hex Washer TekS® Climaseal® 4 Screw complies to Australian Standards AS3566.2 Class 4

Product Technical Data Sheet

10-16 Hex Head Tekes

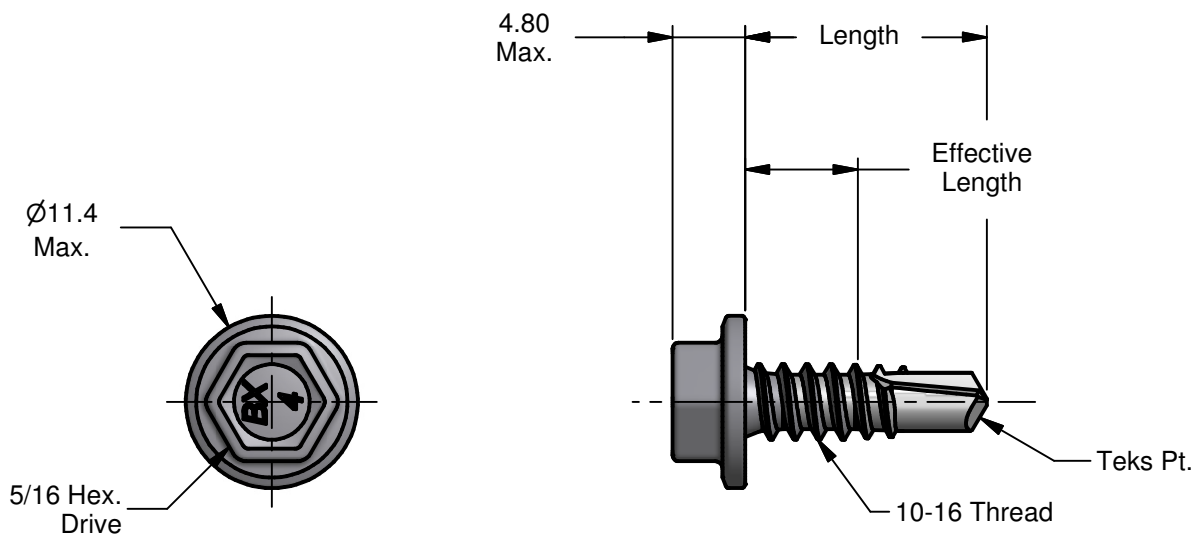

Description	Length	Effective Length
10-16 x 16 Hex Head Tekes Climaseal 4	14.5 / 16.0	6.3 Min.
10-16 x 25 Hex Head Tekes Climaseal 4	23.5 / 25.0	15.3 Min.

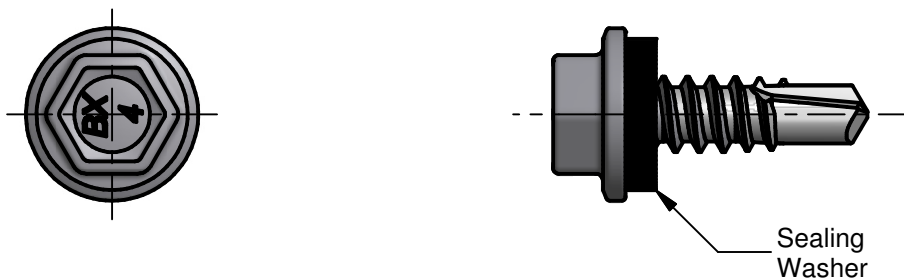

All dimensions nominal unless otherwise stated. Normal manufacturing tolerances apply.

Buildex® Head Office
 600 South Road
 Moorabbin Victoria 3189
 Australia
 1300 368 101
 CustomerService-MBN@buildex.com.au

Buildex® Middle Eastern Sales Office
 middleeastsales@buildex.com.au

Technical Help Desk
 Technicalhelpdesk@buildex.com.au