

Product Technical Data Sheet

14-10 Hex Head TekS®

Part Number	Description	Pack Qty	Pallet Qty
6-311-3323-1C4	14-10 x 25 3/8 Hex Drive Hex Head TekS® Climaseal® 4	500	36,000
6-310-3323-5C4	14-10 x 25 3/8 Hex Drive Hex Head TekS® with Seal Climaseal® 4	500	36,000
6-311-5323-1C5	14-10 x 25 3/8 Hex Drive Hex Head TekS® Climaseal® 5	500	36,000
6-310-5323-5C5	14-10 x 25 3/8 Hex Drive Hex Head TekS® with Seal Climaseal® 5	500	36,000
6-311-3554-7MP	14-10 x 25 5/16 Hex Drive Hex Head TekS® Climaseal® 3	500	36,000

Application:

Buildex® 14-10 Hex Head TekS® Screw is used for fixing metal to metal.

Drill Capacity:

Steel 1.2 mm ~ 2.4 x 2

Features:

Hex Drive
TekS® Point
Finish

Benefits:

For positive drive under high installation torque
For drilling into steel while ensuring maximum pullout strength and a high strip torque.
Corrosion performance Class 3 or Class 4 to suit the application.

Installation Instructions:

1. Use a Buildex® 3/8 Hex Head Driver Bit (1-991-1370) or use a Buildex® 5/16 Hex Head Driver Bit (1-991-1366-9)
2. Use a mains powered or cordless screw driver with a 3,000 RPM speed max.
3. Fit the driver bit into the screw and place at the fastening position.
4. Apply consistently firm pressure (end load) to the screw driver until the screw has fastened.

Material: Carbon Steel SAE 1022 | **Heat Treatment:** To AS 3566.1

Finish: Climaseal® 3 | Climaseal® 4 | Climaseal® 5

Mechanical Properties:

Single Shear Strength (N) 10,900 | Axial Tensile (N) 19,700 | Torsion Strength 18.50 N-m

Pullout Values (N):

Steel Purlin 1,2: 2,600 | Steel Purlin 1,5: 4,680 | Steel Purlin 1,9: 6,500 | Steel Purlin 2,4: 8,100

All values are averages obtained under laboratory conditions and appropriate safety factors should be applied for design purposes.
These figures are applicable to Buildex® head marked product only.

Corrosion Performance:

14-10 Hex Head TekS® Screw complies to Australian Standards AS3566.2 Class 3 and Class 4 and Buildex Category 5
Specify your corrosion performance requirements when ordering.

Product Technical Data Sheet

14-10 Hex Head TekS®

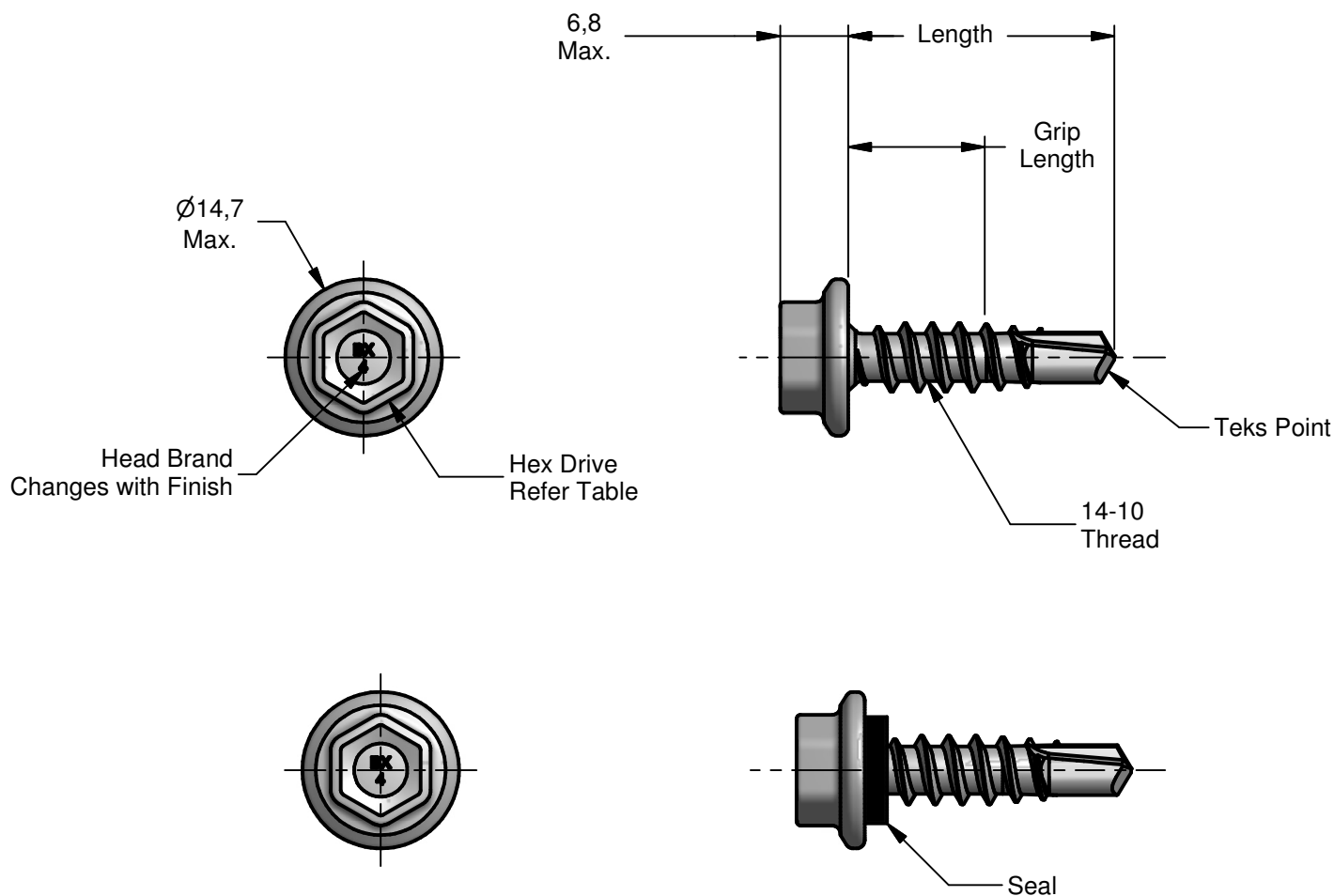

Part Number	Length	Grip Length	Hex Drive	Seal
14-10 x 25 3/8 Hex Drive Hex Head TekS Climaseal 4	23.5 / 25.00	10.8 Min.	3/8 Hex	Yes
14-10 x 25 3/8 Hex Drive Hex Head TekS Climaseal 5	23.5 / 25.00	10.8 Min.	3/8 Hex	Yes
14-10 x 25 5/16 Hex Drive Hex Head TekS Climaseal 3	23.5 / 25.00	10.8 Min.	5/16 Hex	No

All dimensions nominal unless otherwise stated. Normal manufacturing tolerances apply.

Buildex® Head Office
 600 South Road
 Moorabbin Victoria 3189
 Australia
 1300 368 101
 CustomerService-MBN@buildex.com.au
 Technical Help Desk
 Technicalhelpdesk@buildex.com.au