

Product Technical Data Sheet

10 -16 Tamper Resistant Head Tekes

Part Number	Description	Pack Qty	Pallet Qty
6-311-0388-8	10 -16 x 16 Tamper Resistant Head Tekes		

Application:

Buildex 10g -16 x 16 Tamper Resistant Head Tekes Screw is used for security fixing such as grills, signs and side cladding and fixing metal to metal.

A general all purpose metal to metal fixing product where security is a requirement.

Drill Capacity:

Steel 0,75 mm ~ 2,4 x 2

Features:

Trilobular Drive

Teks Point

Finish

Benefits:

Tamper resistant

For drilling into steel while ensuring maximum pullout strength and a high strip torque.

Corrosion performance Class 3.

Installation Instructions:

1. Use a Trilobular Driver Bit (Buildex Part 1-991-0085-7)
2. Use a mains powered or cordless screw driver with a 2,500 RPM speed.
3. Fit the driver bit into the screw and place at the fastening position.
4. Apply consistently firm pressure (end load) to the screw driver until the screw has fastened.

Material:

Carbon Steel SAE 1022

Heat Treatment:

To AS 3566.1

Finish:

To AS 3566.2 Class 3

Mechanical Properties:

Single Shear Strength (N) 6,000 | Axial Tensile (N) 12,000 | Torsion Strength 8,5 N-m

Pullout Values (N):

Batten 0,75: 1,860 | Steel Purlin 1,2: 2,320 | Steel Purlin 1,5: 4,200 | Steel Purlin 1,9: 5,500 | Steel Purlin 2,4: 7,820

All values are averages obtained under laboratory conditions and appropriate safety factors should be applied for design purposes.

These figures are applicable to Buildex head marked product only.

Corrosion Performance:

10 -16 Tamper Resistant Tekes Climaseal 3 Screw complies to Australian Standards AS3566.2 Class 3

Buildex, Tekes and Climaseal are Buildex registered Trademarks

Status Released | Written By John Mallet | Date Written 13/05/2011 | Current Issue 1 | Current Issue Date 13/05/2011

A Division of ITW Buildex Australia Pty Ltd. ACN 004 235 036 ABN 63 004 235 063

Page 1 of 2

Product Technical Data Sheet

10 -16 Tamper Resistant Head Tekes

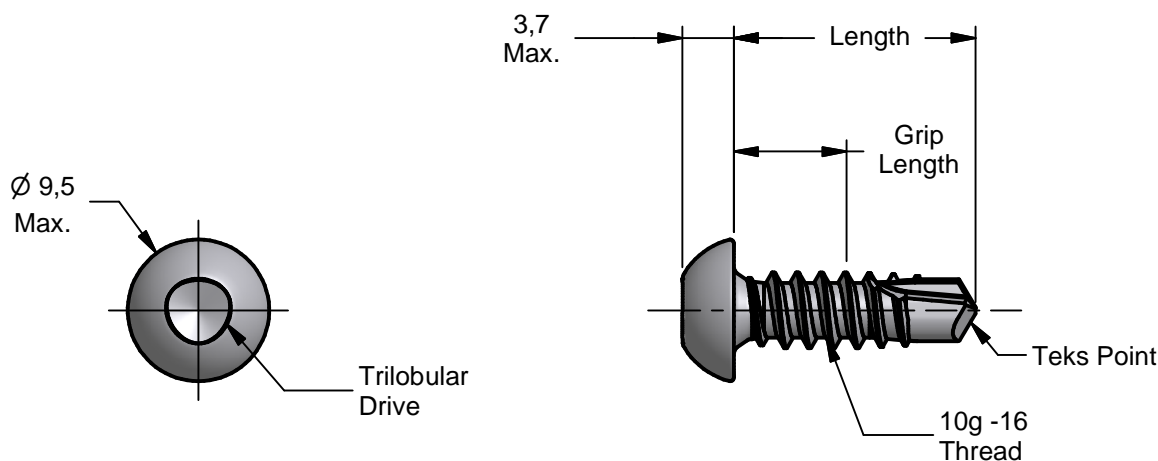

Description	Length	Grip Length
10 -16 x 16 Tamper Resistant Head Tekes	16.0	6,3 Min.

All dimensions nominal unless otherwise stated. Normal manufacturing tolerances apply.

Dr David Collinson
 Technical & Product Development
 Manager Buildex

Alan Brooke
 Quality Assurance
 Manager Buildex

Buildex Head Office
 600 South Road
 Moorabbin Victoria 3189
 Australia
 Customer Service Australia
 CustomerService-MBN@buildex.com.au
 1300 368 101
 Buildex Middle Eastern Sales Office
 Office 309
 Building 3 East
 Dubai Airport Free Zone, UAE
 Customer Service Middle East & Indian
 Subcontinent
 middleeastsales@buildex.com.au
 1300 368 101
 Buildex Website
<http://www.buildex.com.au>
 Technical Help Desk
 Technicalhelpdesk@buildex.com.au
 1300 137 273

Buildex, Tekes and Climaseal are Buildex registered Trademarks

Status Released | Written By John Mallet | Date Written 13/05/2011 | Current Issue 1 | Current Issue Date 13/05/2011