

Product Technical Data Sheet

12 -14 Hex Washer HiGrip® AutoTeks®

Part Number	Description	Pack Qty	Pallet Qty
6-310-3637-7C4	12 -14 x 39 Hex Washer HiGrip® Teks® Climaseal 3 with seal	1000	114,000
6-310-3579-4C4	12 -14 x 52 Hex Washer HiGrip® Teks® Climaseal 3 with seal	1000	84,000

Application:

Buildex® 12 -14 Hex Washer HiGrip® AutoTeks® Screws are used for crest fixing Corrugated and Square Rib Roof Sheets to steel purlins.

The 52 mm Autoteks® Screw are used in conjunction with the AutoTeks® Tool part number 6-991-0401-1 or can be installed with a cordless or mains powered screw driver.

Drill Capacity:

Steel 1.2 mm ~ 2.4 mm x 2

Features:

AutoTeks Hex Drive

HiGrip® Thread

Shank Guard®

Teks® Point

Finish

AutoTeks® Tool

Benefits:

For positive drive under high installation torque

Stop sheet from moving when the roof is walked on.

Protects the shank from scratching and scouring during installation

For drilling into steel while ensuring maximum pullout strength and a high strip torque.

Corrosion performance Climaseal® 4.

Multifeed Autoteks tool is used to decrease fatigue and increase efficiency and allows feeding 12 screws at one time.

Installation (standard screwdriver) Instructions:

1. Use a Buildex® $\frac{5}{16}$ Hex Head Driver Bit (1-991-1366-9)
2. Use a mains powered or cordless screw driver with a 3,000 RPM max.
3. Fit the $\frac{5}{16}$ driver bit into the screw and place at the fastening position.
4. Apply consistently firm pressure (end load) to the screw driver until the screw has fastened.

Installation (AutoTeks® Tool) instructions for 52 mm AutoTeks® Screw:

Refer AutoTeks® Manual 01075-PDS

Material: Carbon Steel SAE 1022 | **Heat Treatment:** To AS 3566.1 | **Finish:** Climaseal® 4

Mechanical Properties:

Single Shear Strength (N) 8,800 | Axial Tensile (N) 15,300 | Torsion Strength 13,20 N-m

Pullout Values (N):

Steel Purlin 1.2 mm: 2,200 | Steel Purlin 1.5 mm: 4,080 | Steel Purlin 1.9 mm: 5,420 | Steel Purlin 2.4 mm: 7,360

All values are averages obtained under laboratory conditions and appropriate safety factors should be applied for design purposes.

These figures are applicable to Buildex® head marked product only.

Corrosion Performance:

The Buildex® 12 -14 Hex Washer HiGrip® AutoTeks® Screw complies to Australian Standards AS3566.2 Class 4

Product Technical Data Sheet

12 -14 Hex Washer HiGrip® AutoTeks®

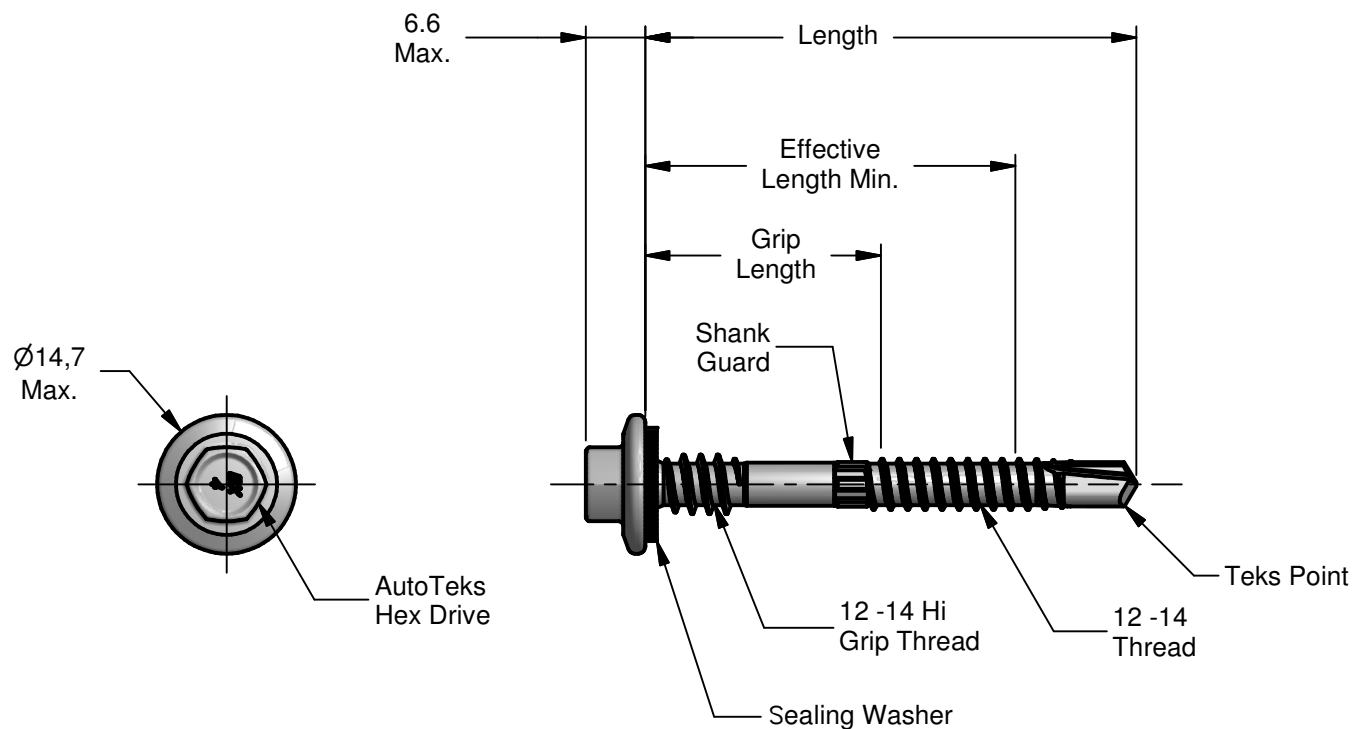

Description	Length	Grip Length	Effective Length
12 -14 x 39 Hex Washer HiGrip® AutoTeks®	37.5 / 39.0	13.0 / 15.0	21.5
12 -14 x 52 Hex Washer HiGrip® AutoTeks®	50.5 / 52.0	22.0 / 24.0	35.5

All dimensions nominal unless otherwise stated. Normal manufacturing tolerances apply.

Buildex® Head Office
 600 South Road
 Moorabbin Victoria 3189
 Australia
 1300 368 101
 CustomerService-MBN@buildex.com.au
 Technical Help Desk
 Technicalhelpdesk@buildex.com.au