

Product Technical Data Sheet

12-24 Hex Washer SuperTeks Series 500

Part Number	Description	Pack Qty	Pallet Qty
6-351-0001-5CS	12-24 x 38.0 Hex Washer SuperTeks Series 500 Climaseal 3	1000	108,000
6-351-0009-4CS	12-24 x 38.0 Hex Washer SuperTeks Series 500 Climaseal 3 with Seal	1000	108,000

Application:

Buildex 12-24 Hex Washer SuperTeks Screw is used for metal to metal fixing of thick steel purlin and hot rolled steel. Used for metal to metal fixing in the HAVAC, plumbing and steel fabrication industries where thick steel section is in use. A general all purpose metal to thick metal fixing product.

Drill Capacity:

Steel 2,4 mm x 2 ~ 12,0 mm

Features:

Hex Drive
Teks Point
Finish

Benefits:

For positive drive under high installation torque
For drilling into thick steel while ensuring maximum pullout strength and a high strip torque.
Corrosion performance Class 3.

Installation Instructions:

1. Use a $\frac{5}{16}$ Hex Head Driver Bit (Buildex Part 1-991-1366-9)
2. Use a mains powered or cordless screw driver with a 2,500 RPM speed.
3. Fit the $\frac{5}{16}$ driver bit into the screw and place at the fastening position.
4. Apply consistently firm pressure (end load) to the screw driver until the screw has fastened.

Material:

Carbon Steel SAE 1022

Heat Treatment:

To AS 3566.1

Finish:

To As 3566.2 Class 3

Mechanical Properties:

Single Shear Strength (N) 9,000 | Axial Tensile (N) 16,700 | Torsion Strength 13,50 N-m

Pullout Values (N):

Steel Purlin 2,4: 6,250 | *Steel HRS 6,0: 16,700 | *Steel HRS 8,00: 16,700 | *Steel HRS 12,00: 16,700

* Denotes screw failed in axial tensile

All values are averages obtained under laboratory conditions and appropriate safety factors should be applied for design purposes.

These figures are applicable to Buildex head marked product only.

Corrosion Performance:

12 -24 Hex Washer Teks Screw complies to Australian Standards AS3566.2 Class 3

Buildex, Teks and Climaseal are Buildex registered Trademarks

Status Released | Written By John Mallet | Date Written 29/12/2010 | Current Issue 2 | Current Issue Date 2/01/2011

A Division of ITW Buildex Australia Pty Ltd. ACN 004 235 036 ABN 63 004 235 063

Page 1 of 2

Product Technical Data Sheet

12-24 Hex Washer SuperTeks Series 500

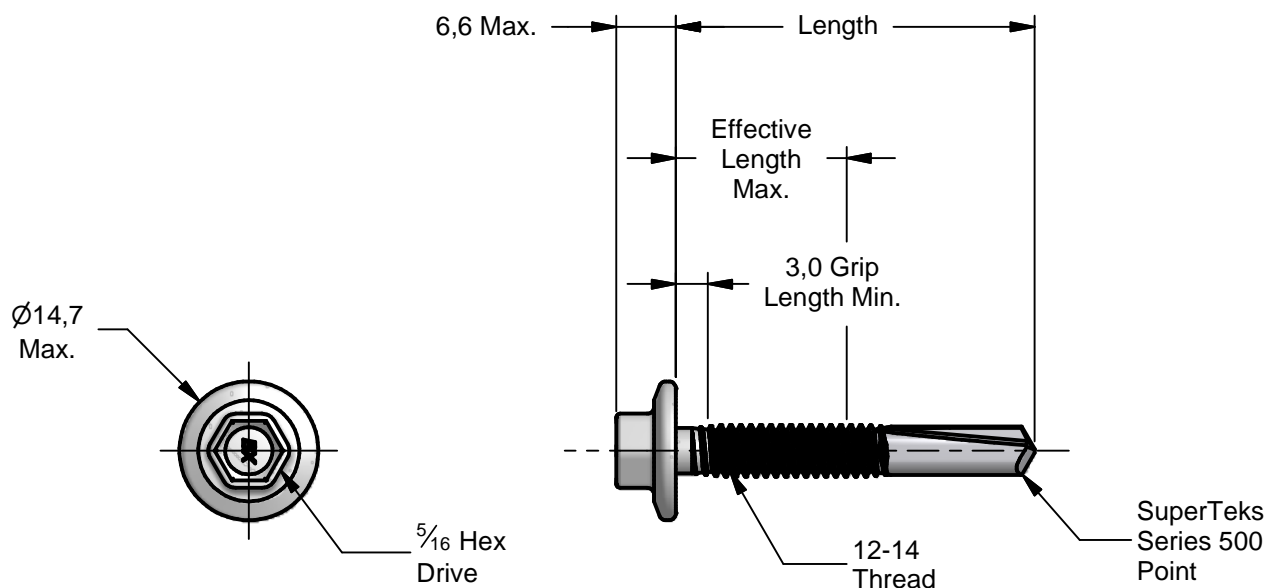

Description	Length	Effective Length
12g -24 x 38.0 Hex Washer SuperTeks Series 500	38.0	16.0

All dimensions nominal unless otherwise stated. Normal manufacturing tolerances apply.

Dr David Collinson
 Technical & Product Development
 Manager Buildex

Alan Brooke
 Quality Assurance
 Manager Buildex

Buildex Head Office
 600 South Road
 Moorabbin Victoria 3189
 Australia
 Customer Service Australia
 CustomerService-MBN@buildex.com.au
 1300 368 101
 Buildex Middle Eastern Sales Office
 Office 309
 Building 3 East
 Dubai Airport Free Zone, UAE
 Customer Service Middle East & Indian
 Subcontinent
 middleeastsales@buildex.com.au
 1300 368 101
 Buildex Website
<http://www.buildex.com.au>
 Technical Help Desk
 Technicalhelpdesk@buildex.com.au
 1300 137 273

Buildex, Teks and Climaseal are Buildex registered Trademarks

Status Released | Written By John Mallet | Date Written 29/12/2010 | Current Issue 2 | Current Issue Date 2/01/2011