

## Product Technical Data Sheet

### 12-24 Hex Head Super Tekes Series 500

Part Number	Description	Pack Qty	Pallet Qty
6-351-0016-1CS	12-24 x 53 Hex Head Super Tekes Series 500 Climaseal 3	1000	84,000
6-350-0016-1CS	12-24 x 53 Hex Head Super Tekes Series 500 with Seal Climaseal 3	1000	84,000
6-351-0017-9CS	12-24 x 68 Hex Head Super Tekes Series 500 Climaseal 3	1000	72,000
6-350-0017-9CS	12-24 x 68 Hex Head Super Tekes Series 500 with Seal Climaseal 3	1000	72,000

#### Application:

Buildex® 12-24 Hex Head SuperTekes® Screw is used for metal to metal fixing of thick steel purlin and hot rolled steel. Used for metal to metal fixing in the HAVAC, plumbing and steel fabrication industries where thick steel section is in use. A general all purpose metal to thick metal fixing product.

#### Drill Capacity:

Steel 2.4 mm x 2 ~ 12,0 mm

#### Features:

Hex Drive  
Tekes® Point  
Finish

#### Benefits:

For positive drive under high installation torque  
For drilling into thick steel while ensuring maximum pullout strength and a high strip torque.  
Corrosion performance Class 3.

#### Installation Instructions:

1. Use a Buildex®  $\frac{5}{16}$  Hex Head Driver Bit (1-991-1366-9)
2. Use a mains powered or cordless screw driver with a 2,500 RPM speed.
3. Fit the  $\frac{5}{16}$  driver bit into the screw and place at the fastening position.
4. Apply consistently firm pressure (end load) to the screw driver until the screw has fastened.

#### Material:

Carbon Steel SAE 1022

#### Heat Treatment:

To AS 3566.1

#### Finish:

To AS 3566.2 Class 3

#### Mechanical Properties:

Single Shear Strength (N) 9,000 | Axial Tensile (N) 16,700 | Torsion Strength 13.50 N-m

#### Pullout Values (N):

Steel Purlin 2,4: 6,250 | \*Steel HRS 6,0: 16,700 | \*Steel HRS 8,00: 16,700 | \*Steel HRS 12,00: 16,700

\* Denotes screw failed in axial tensile

All values are averages obtained under laboratory conditions and appropriate safety factors should be applied for design purposes.

These figures are applicable to Buildex® head marked product only.

#### Corrosion Performance:

12 -24 Hex Head Tekes® Screw complies to Australian Standards AS3566.2 Class 3

## Product Technical Data Sheet

### 12-24 Hex Head Super Teks Series 500

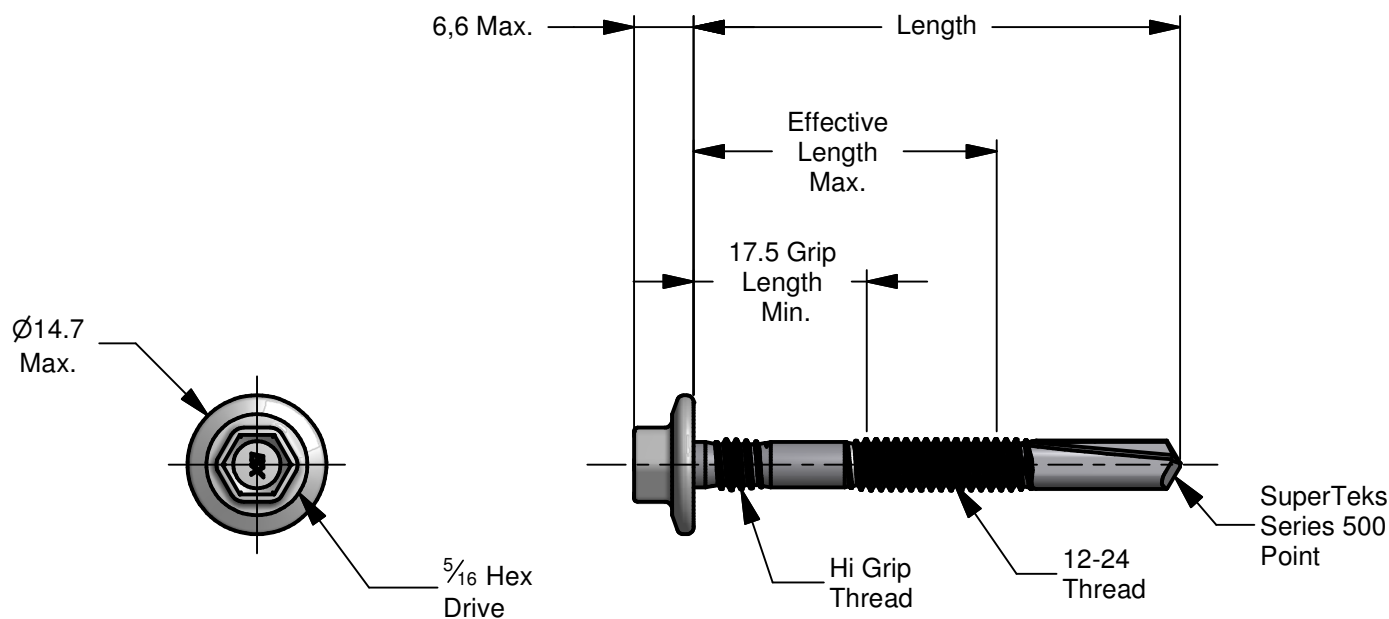

Description	Length	Effective Length
12 -24 x 53 Hex Head SuperTeks® Series 500	51.5 / 53.0	31.0 Min.
12 -24 x 68 Hex Head SuperTeks® Series 500	66.5 / 68.0	46.0 Min.

All dimensions nominal unless otherwise stated. Normal manufacturing tolerances apply.

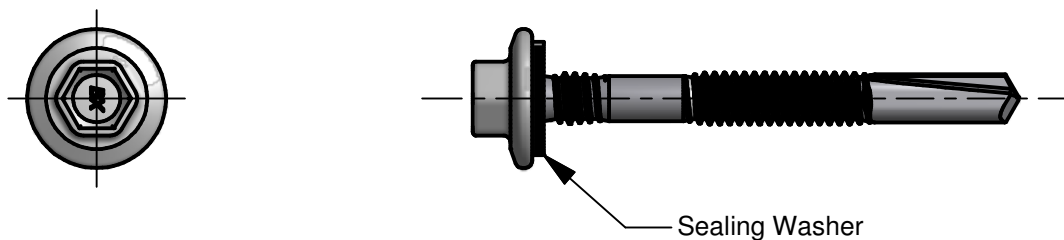

Buildex® Head Office  
 600 South Road  
 Moorabbin Victoria 3189  
 Australia  
 1300 368 101  
 CustomerService-MBN@buildex.com.au  
 Technical Help Desk  
 Technicalhelpdesk@buildex.com.au