

## Product Technical Data Sheet

### 10-12 Hex Washer Type 17

Part Number	Description	Pack Qty	Pallet Qty
6-031-0063-2CS	10-12 x 20 Hex Washer Type 17 Climaseal 3	1,000 / 4,000	288,000
6-030-0048-8CS	10-12 x 20 Hex Washer Type 17 with Neo Climaseal 3	1,000 / 3,000	216,000
6-031-0053-8CS	10-12 x 25 Hex Washer Type 17 Climaseal 3	1,000 / 3,000	216,000
6-030-0001-2CS	10-12 x 25 Hex Washer Type 17 with Neo Climaseal 3	1,000 / 3,000	216,000
6-031-0005-1CS	10-12 x 30 Hex Washer Type 17 Neo Climaseal 3	1,000 / 3,000	216,000
6-030-0068-7CS	10-12 x 30 Hex Washer Type 17 with Neo Climaseal 3	1,000 / 3,000	216,000

#### Application:

Buildex® 10-12 Hex Washer Type 17 are designed for a variety of applications for fixing to timbers - fencing - furniture - pergolas and side cladding .

#### Drilling Capacity:

Timber F7 to F27

#### Installation Instructions:

1. Use a 5/16 Driver Bit (Buildex® Part Number 1-991-1366-9).
2. Use a mains powered or cordless screw driver with a 2,500 RPM speed.
3. Fit the Driver Bit into the screw and place at the fastening position.
4. Apply consistently firm pressure (end load) to the screw driver until the screw has drilled and fastened.

**Material:** Carbon Steel SAE 1022 | **Heat Treatment:** To AS 3566.1 | **Finish:** Zinc Plate or Climaseal® 3

#### Mechanical Properties:

Single Shear Strength (N) 8,100 | Axial Tensile Strength (N) 9,400 | Torsion Strength (Nm) 7.3

#### Pullout Values:

20 mm Embedment : F5 (Pine) Timber (N) 3,000 | F8 Timber (N) 2,300 | F17 (Hardwood) Timber (N) 3,800

25 mm Embedment : F5 (Pine) Timber (N) 3,800 | F8 Timber (N) 3,500 | F17 (Hardwood) Timber (N) 5,200

30 mm Embedment : F5 (Pine) Timber (N) 3,800 | F8 Timber (N) 3,900 | F17 (Hardwood) Timber (N) 6,000

All values are averages obtained under laboratory conditions and appropriate safety factors should be applied for design purposes.

These figures are applicable to Buildex® head marked product only.

#### Corrosion Performance:

Buildex® 10-12 Hex Washer Type 17 with the Climaseal® 3 finish complies to Australian Standards AS3566.2 Class 3

Specify your corrosion performance requirements when ordering

## Product Technical Data Sheet

### 10-12 Hex Washer Type 17

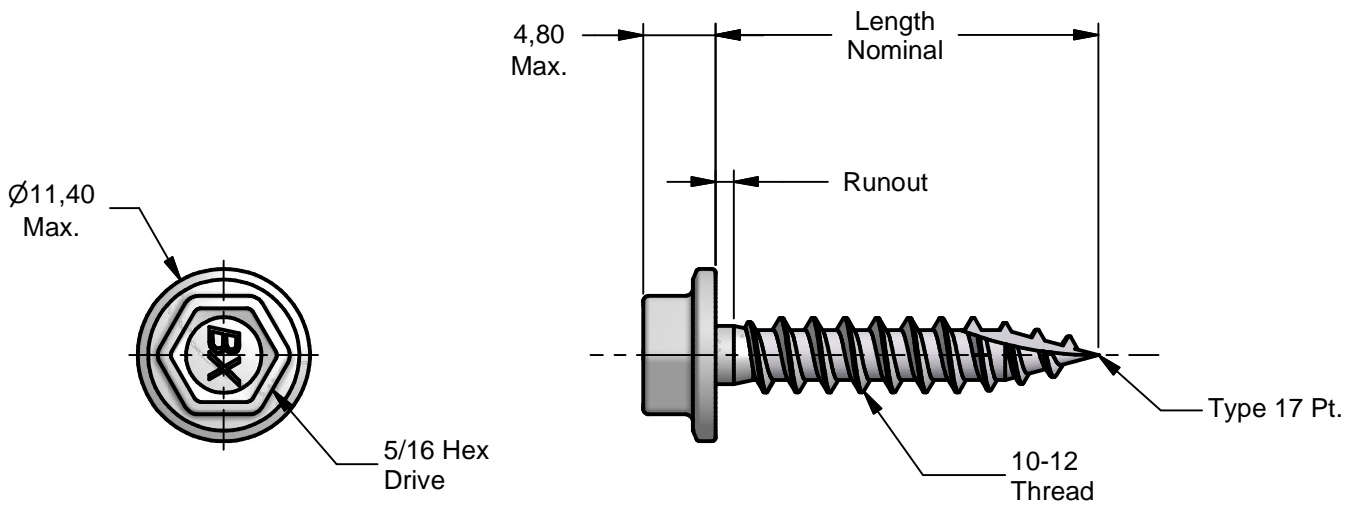

Description	Length	Runout
10-12 x 20 Hex Washer T17	18.5 / 20.0	1.4 Max.
10-12 x 25 Hex Washer T17	23.5 / 25.0	1.4 Max.
10-12 x 30 Hex Washer T17	28.5 / 30.0	1.4 Max.

All dimensions nominal unless otherwise stated. Normal manufacturing tolerances apply.

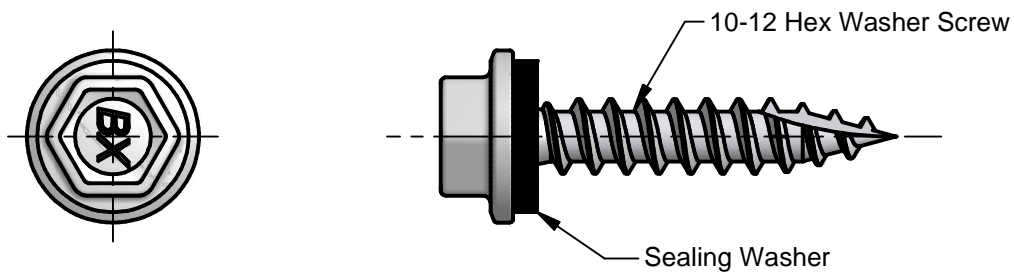

Buildex® Head Office  
 600 South Road  
 Moorabbin Victoria 3189  
 Australia  
 1300 368 101  
 CustomerService-MBN@buildex.com.au

Buildex® Middle Eastern Sales Office  
 middleeastsales@buildex.com.au

Technical Help Desk  
 Technicalhelpdesk@buildex.com.au