

Product Technical Data Sheet

12-11 Hex Washer Type 17

Part Number	Description	Pack Qty	Pallet Qty
6-031-3097-9C4	12-11 x 25 Hex Washer Type 17 Climaseal® 4	500 / 2000	144,000
6-030-3012-1C4	12-11 x 25 Hex Washer Type 17 Climaseal® 4 with Seal	500 / 2000	144,000

Application:

Buildex® 12-11 Hex Washer Type 17 is designed for valley fixing roof sheet or side cladding to timber battens or fixing heavy timbers - fencing - furniture - pergolas - general timber frame or truss assembly.

Drilling Capacity:

Timber F7 to F27

Features:

Hex Drive
Shank Guard
Finish

Benefits:

For positive drive under high installation torque
Protects the shank from scratching and scouring during installation
Corrosion performance Class 4.

Installation Instructions:

1. Use a 5/16 Hex Head Driver Bit (Buildex® Part 1-991-1366-9).
2. Use a mains powered or cordless screw driver with a 2,500 RPM speed.
3. Fit the driver bit into the screw and place at the fastening position.
4. Apply consistently firm pressure (end load) to the screw driver until the screw has fastened.

Material: Carbon Steel SAE 1022 | **Heat Treatment:** To AS 3566.1 | **Finish:** Climaseal 4

Mechanical Properties:

Single Shear Strength (N) 8,400 | Axial Tensile Strength (N) 13,900 | Torsion Strength (Nm) 13.5

Pullout Values:

Into F7 (Pine) Timber (N) 2,400 | Into F17 (Hardwood) Timber (N) 3,300

All values are averages obtained under laboratory conditions and appropriate safety factors should be applied for design purposes.

These figures are applicable to Buildex® head marked product only.

Pullout values at 20.0 mm embedment

Corrosion Performance:

Buildex® 12-11 Hex Washer Type 17 with the Climaseal® 4 finish complies to Australian Standards AS3566.2 Class 4

Product Technical Data Sheet

12-11 Hex Washer Type 17

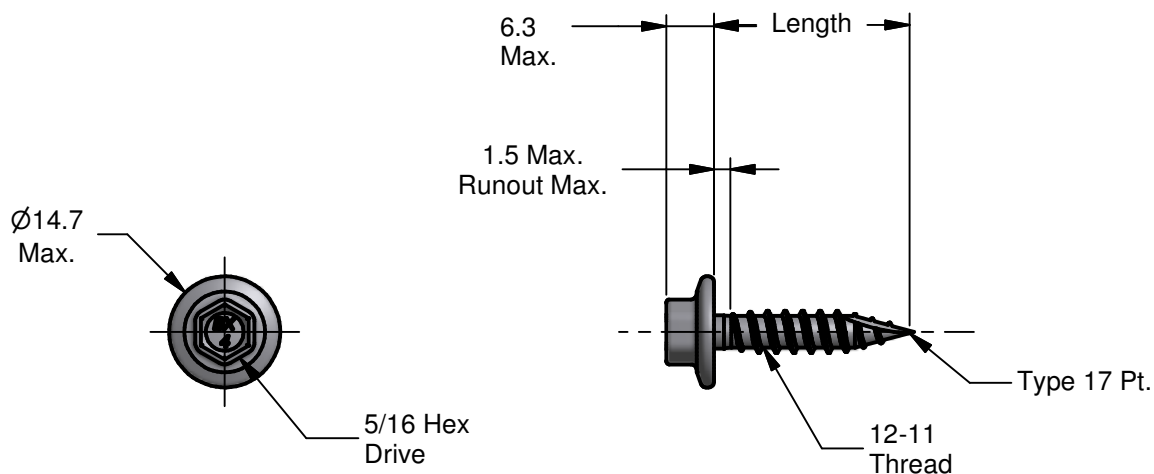

Description	Length
12-11 x 25 Hex Washer Type 17 Climaseal® 4	23.5 / 25.0

All dimensions nominal unless otherwise stated. Normal manufacturing tolerances apply.

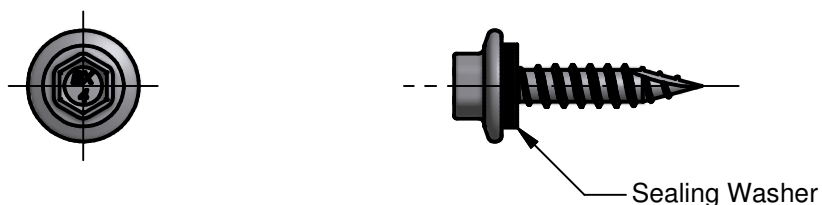

Buildex® Head Office
 600 South Road
 Moorabbin Victoria 3189
 Australia
 1300 368 101
 CustomerService-MBN@buildex.com.au

Buildex® Middle Eastern Sales Office
 middleeastsales@buildex.com.au

Technical Help Desk
 Technicalhelpdesk@buildex.com.au