

Product Technical Data Sheet

14-10 Hex Head T17

Part Number	Description	Pack Qty	Pallet Qty
6-031-5008-2C5	14-10 x 50 Hex Head Type 17 Climaseal 5	500/ 1500	108,000
6-030-5007-1C5	14-10 x 50 Hex Head Type 17 with Seal Climaseal 5	1000	105,000
6-036-5008-2C5	14-10 x 50 Hex Head Type 17 Multiseal Climaseal 5	250	18,000

Application:

Buildex® 14-10 Hex Head Type 17 are designed for pierce Crest fixing cladding to timber. The Buildex® Available either bare, with sea, cyclone plate and MultiSeal® Washer.

Drilling Capacity:

Timber F7 ~ F27

Features:

Hex Drive
Type 17 Point
Finish

Benefits:

For positive drive under high installation torque
For easy installation into timber
Corrosion performance of Climaseal 5 to suit the application.

Installation Instructions:

1. Use a Buildex® 3/8 Hex Hexagon Driver Bit (1-991-1370-4).
2. Use a mains powered or cordless screw driver with a 3,000 RPM max. speed.
3. Fit the hex driver bit over the screw and place at the fastening position.
4. Apply consistently firm pressure (end load) to the screw driver until the screw has drilled and fastened.

Material:

Carbon Steel SAE 1022 | **Heat Treatment:** To AS 3566.1 | **Finish:** Climaseal® 5

Mechanical Properties:

Single Shear Strength (N) 10,900 | Axial Tensile Strength (N) 19,700 | Torsion Strength (Nm) 18.5

Pullout Values (35.0 mm embedment):

F7 (Pine) Timber (N) 3,820 | F17 (Hardwood) Timber (N) 6,980

All values are averages obtained under laboratory conditions and appropriate safety factors should be applied for design purposes.

These figures are applicable to Buildex® head marked product only.

Corrosion Performance:

Buildex® 14-10 Hex Head Type 17 Climaseal 5® screws Suitable for ISO 9223 Category 4 and 5

Product Technical Data Sheet

14-10 Hex Head T17

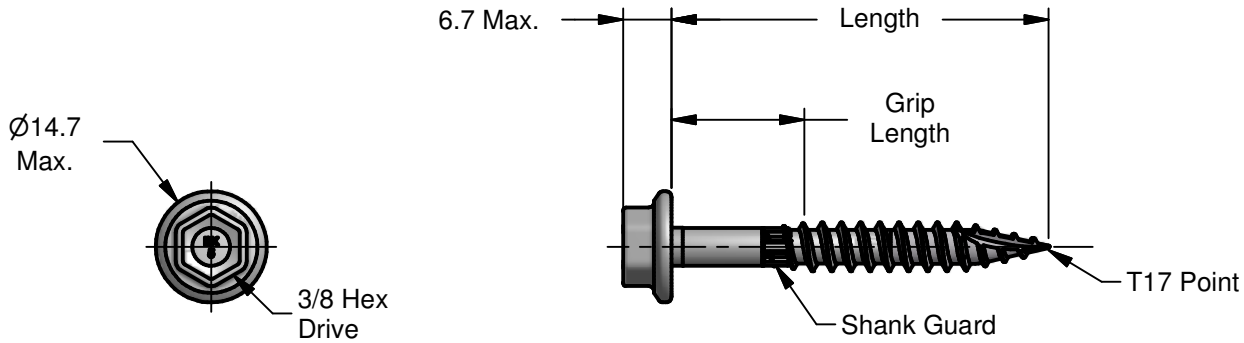

Description	Length	Grip Length
14-10 x 50 Hex Head Type 17 Climaseal 5	48.5 / 50.0	17.75 Max,

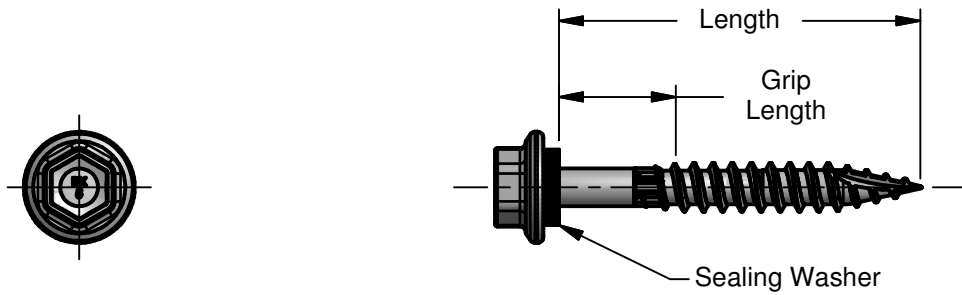

Description	Length	Grip Length
14-10 x 50 Hex Head Type 17 with Seal Climaseal 5	48.5 / 49.5	17.25 Min.

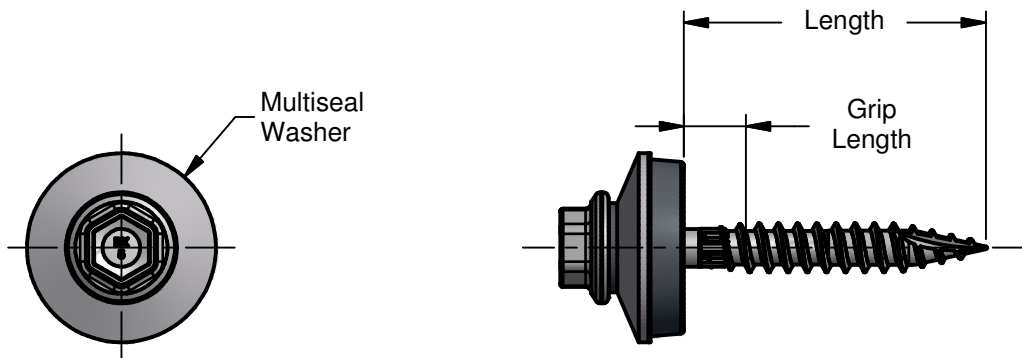

Description	Length	Grip Length
14-10 x 50 Hex Head Type 17 Multiseal Climaseal 5	37.5 / 39.0	6.75 Min.

Buildex® Head Office
 600 South Road
 Moorabbin Victoria 3189
 Australia
 1300 368 101
 CustomerService-MBN@buildex.com.au
 Technical Help Desk
 Technicalhelpdesk@buildex.com.au

All dimensions in mm and nominal unless otherwise stated. Normal manufacturing tolerances apply.