

Product Technical Data Sheet

10 -16 Designer Head

Part Number	Description	Pack Qty	Pallet Qty
6-031-3326-6C4	10 -16 x 25 Designer Head Climaseal® 4	1000 / 3000	252,000
6-030-3326-6C4	10 -16 x 25 Designer Head with Seal Climaseal® 4	1000 / 3000	252,000

Application:

Buildex® 10 -16 Designer Head Screw is designed for valley fixing roof sheet or side cladding to timber battens and steel purlins.

The product is available with a sealing washer and head painted to match all popular roofing and cladding colours.

Drilling Capacity:

Steel 0.75 mm ~ 3.0 mm thick | Timber F5 to F17

Features:

Hex Drive
Head Head
Drill Point
Finish

Benefits:

For positive drive under high installation torque
Non Indented Hex Head for decorative side cladding.
Drill Point suitable for steel and timber.
Corrosion performance Climaseal® 4

Installation Instructions:

1. Use a 5/16 Hex Head Driver Bit (Buildex® Part 1-991-1366-9).
2. Use a mains powered or cordless screw driver with a 2,500 RPM speed.
3. Fit the driver bit into the screw and place at the fastening position.
4. Apply consistently firm pressure (end load) to the screw driver until the screw has fastened.

Material: Carbon Steel SAE 1022 | **Heat Treatment:** To AS 3566.1 | **Finish:** Climaseal® 4

Mechanical Properties:

Single Shear Strength (N) 6,000 | Axial Tensile Strength (N) 12,000 | Torsion Strength (Nm) 8.5

Pullout Values:

Batten 0.75 mm 1,860 | Steel Purlin 1.2 mm 2,320 | Steel Purlin 1.5 mm 4,200 | 1.9 mm 5,500 | Steel Purlin 2.4 mm 7,820

Into F5 (Pine) Timber (N) 3,800 | Into F8 Timber 3,500 | Into F17 (Hardwood) Timber (N) 5,200

All values are averages obtained under laboratory conditions and appropriate safety factors should be applied for design purposes.

These figures are applicable to Buildex® head marked product only.

Pullout values at 25.0 mm embedment

Corrosion Performance:

Buildex® 10-16 Designer Head with the Climaseal® 4 finish complies to Australian Standards AS3566.2 Class 4

Product Technical Data Sheet

10 -16 Designer Head

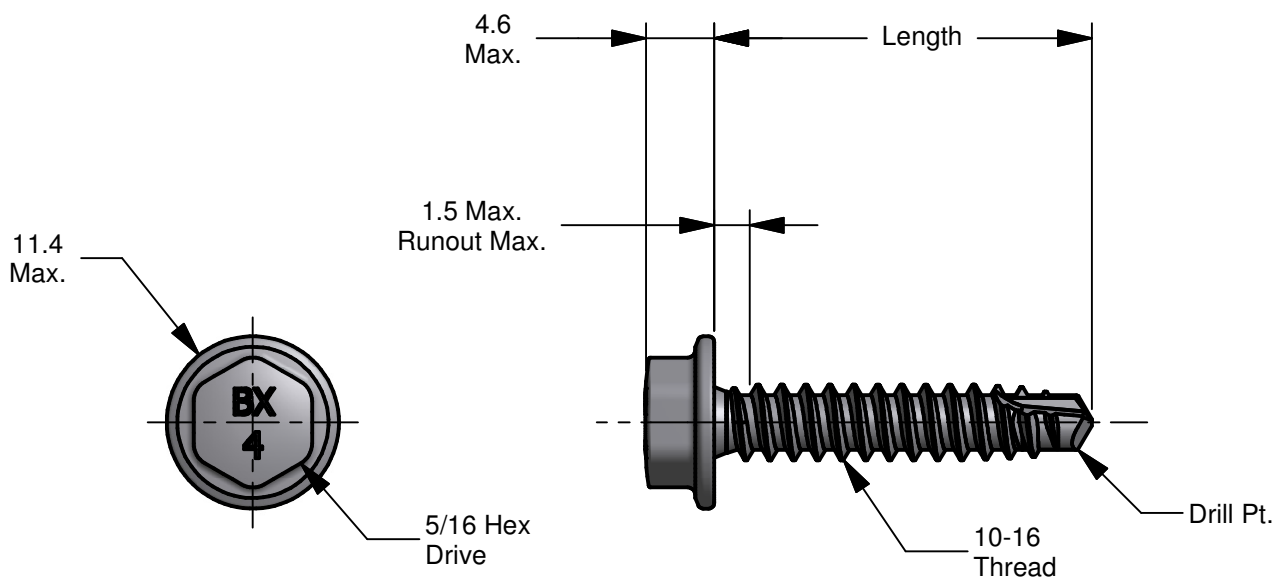

Description	Length
10 -16 x 25 Designer Head Climaseal® 4	23.5 / 25.0

All dimensions nominal unless otherwise stated. Normal manufacturing tolerances apply.

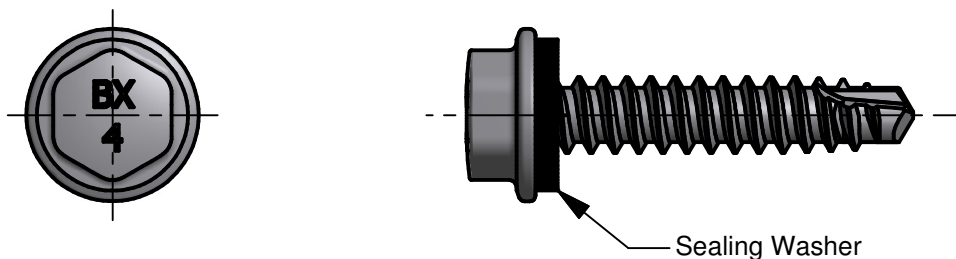

Buildex® Head Office
 600 South Road
 Moorabbin Victoria 3189
 Australia
 1300 368 101
 CustomerService-MBN@buildex.com.au

Buildex® Middle Eastern Sales Office
 middleeastsales@buildex.com.au

Technical Help Desk
 Technicalhelpdesk@buildex.com.au